

Séries  
NSX

SIZE 5 PIN COAX CONTACT  
FOR RAYCHEM 5012K1011 CABLE  
BOEING P/N: BACC47EV-2

Issue:  
09 FEB. 94

Page  
1 / 1

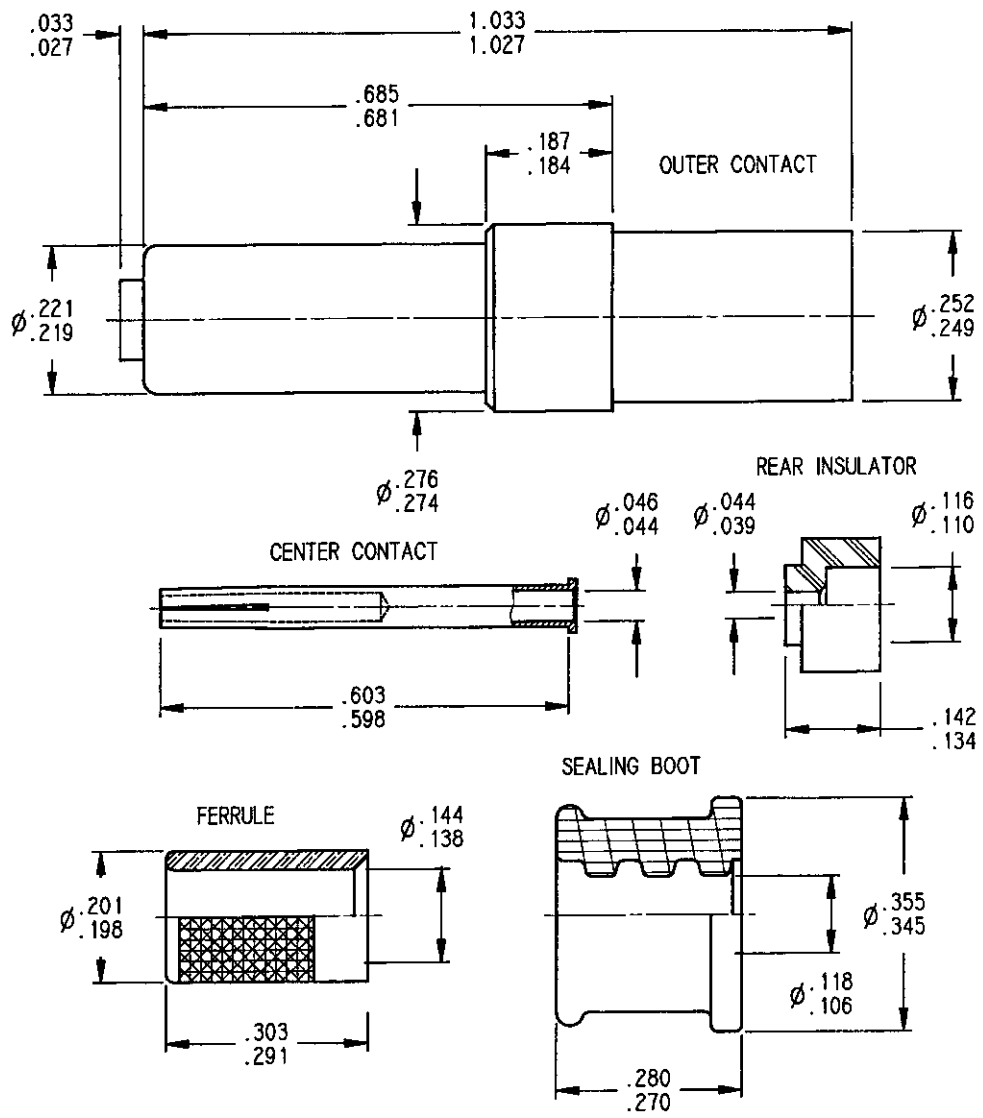

**MATERIAL:**  
 OUTER CONTACT: BRASS PER QQ-B 626  
 INSULATOR: TPFE  
 CENTER CONTACT: BERYLLIUM COPPER HEAT TREATED FOR SPRING TINES \_ANNEALED ON CRIMP BARREL'  
 FERRULE: BRASS  
 SEALING BOOT: SILICONE ELASTOMER  
**FINISH (ALL METAL PARTS)**  
 GOLD PLATE PER MIL\_G\_45204:50 MICROINCHES OVER NICKEL

**DESIGN REQUIREMENTS**  
 TEMPERATURE RANGE: -65°C TO +165°C  
 IMPEDANCE: 50 OHMS NOMINAL  
 RATED VOLTAGE: 325 V RMS AT SEA LEVEL  
 VSWR: 1,30:1  
 FREQUENCY RANGE: 0 - 500 MHZ  
 CONTACT RESISTANCE: 1.0 MILLIOHMS MAX (OUTER CONTACT)  
 DIELECTRIC WITHSTANDING VOLTAGE: 750 VRMS AT SEA LEVEL

CONTACT SHALL ASSEMBLE USING TOOLING AND STRIP LENGTHS ACCORDING TO RP08710

This information is given as an indication. In the continual goal to improve our products, we reserve the right to make any modifications judged necessary.

CREATION				
PEN: .				
NOM: JP MACARI				
DATE: 23 DEC. 93	09.02.94	CHANGE FERRULE SHAPE Ø.201/.198 WAS .193/.191	JP MACARI	<i>CALENE</i>
APPR.: <i>CALENE</i>	Issue	Revisions	Name	Approved